

# SFB series Installation Manual

All-glass Evacuated Tubular Solar Collector with Heat Pipe

## Contents

1. Solar collector size and weight: .....	2
2. How to transport and carry it? .....	2
3. Installation.....	3
3.1 Unpack and inspection.....	3
3.2 Fix the Frames and Manifold Box: .....	7
3.2.1 Put Side Rails: .....	7
3.2.2 Fix the Manifold: .....	8
3.3 Fix the bottom rail: .....	9
3.4 Fix solar collector on your sloping roof .....	10
3.4.1 Sloping roof .....	10
3.4.2 Flat roof .....	13
3.5 Install the tubes .....	13
4. Lightning protection.....	16
5. How to connect couple of collectors? .....	16
6. Connection of the collector field to the heat transfer circuit.....	16
7. Dimensions of pipe connections .....	18
8. Heat Transfer Media .....	18
9. Precautions .....	18
10. Max. working pressure.....	19
11. Pressure Drop.....	19
12. Installation Angle.....	19
13. Wind and snow load .....	20
14. Maintenance Requirements .....	20
14.1 Cleaning .....	20
14.2 Leaves .....	20
14.3 Broken Tube .....	20

Please begin to assemble after you read over the manual carefully!

## 1. Solar collector size and weight:

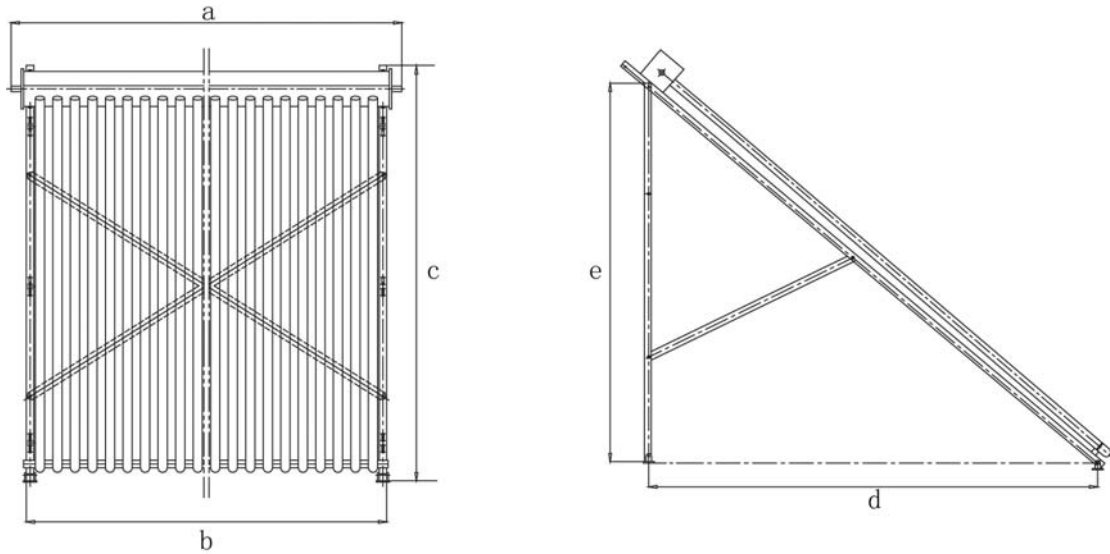

Item No.	Specification			Weight Kg	size(mm)				
	Qty. of solar tubes	Diameter of solar tube	Length of solar tube		a	b	c	d	e
SFB104715	10pcs	Ø 47mm	1.5M	32	870	750	1660	1174	1000
SFB204715	20pcs	Ø 47mm	1.5M	54	1570	1450	1660	1174	1000
SFB304715	30pcs	Ø 47mm	1.5M	76	2270	2150	1660	1174	1000
SFB105818	10pcs	Ø 58mm	1.8M	50	960	840	1960	1398	1200
SFB205818	20pcs	Ø 58mm	1.8M	115	1760	1640	1960	1398	1200
SFB305818	30pcs	Ø 58mm	1.8M	122	2560	2440	1960	1398	1200

## 2. How to transport and carry it?

Please handle manifold flatly. It's forbidden to handle it vertically.

Please handle glass tubes carefully and flatly. It's forbidden to handle it vertically.

If you want to transport your solar collector in long distance, it's better to put tubes at bottom and make sure it won't move in transportation. To save space, you can put manifold on catons of glass tubes. And do the best to drive carefully, avoiding bumpy road.

### 3. Installation

#### 3.1 Unpack and inspection

##### SFB104715

No.	Items	Qty.(pcs)	Qty. of spare part	Total	
1	Manifold box	1		1	
2	SFVB (All-glass Evacuated Tubular Solar Collector with Heat Pipe,Φ47mm*1500mm)	10		10	
3	Thermal silicon grease (80g)	1		1	
4	Decoration cover	10	1	11	
5	Vertical bar	2		2	
6	Aluminum horizontal bar	1		1	
7	Black nylon screw cup	10	1	11	
8	Reflectors	9		9	
9	White Nylon clips for reflectors	18		18	
10	screw ,washer and nut	M8×10 (screw,nut,washer)	4	1	5
		M6×10 (screw+washer) they have been on the manifold	4	1	5

**SFB204715**

No.	Items	Qty.(pcs)	Qty. of spare part	Total	
1	Manifold box	1		1	
2	SFVB (All-glass Evacuated Tubular Solar Collector with Heat Pipe,Φ47mm*1500mm)	20		20	
3	Thermal silicon grease (80g)	1		1	
4	Decoration cover	20	1	21	
5	Vertical bar	2		2	
6	Aluminum horizontal bar	1		1	
7	Black nylon screw cup	20	1	21	
8	Reflectors	19		19	
9	White Nylon clips for reflectors	38		38	
10	screw ,washer and nut	M8×10 (screw,nut,washer)	4	1	5
		M6×10 (screw+washer) they have been on the manifold	4	1	5

**SFB304715**

No.	Items	Qty.(pcs)	Qty. of spare part	Total	
1	Manifold box	1		1	
2	SFVB (All-glass Evacuated Tubular Solar Collector with Heat Pipe,Φ47mm*1500mm)	30		30	
3	Thermal silicon grease (80g)	1		1	
4	Decoration cover	30	1	31	
5	Vertical bar	3		3	
6	Aluminum horizontal bar	1		1	
7	Black nylon screw cup	30	1	31	
8	Reflectors	29		29	
9	White Nylon clips for reflectors	58		58	
10	screw ,washer and nut	M8×10 (screw,nut,washer)	6	1	7
		M6×10 (screw+washer) they have been on the manifold	6	1	7

**SFB105818**

No.	Items	Qty.(pcs)	Qty. of spare part	Total	
1	Manifold box	1		1	
2	SFVB (All-glass Evacuated Tubular Solar Collector with Heat Pipe,Φ58mm*1800mm)	10		10	
3	Thermal silicon grease (80g)	1		1	
4	Decoration cover	10	1	11	
5	Vertical bar	2		2	
6	Aluminum horizontal bar	1		1	
7	Black nylon screw cup	10	1	11	
8	Reflectors	9		9	
9	White Nylon clips for reflectors	18		18	
10	screw ,washer and nut	M8×10 (screw,nut,washer)	4	1	5
		M6×10 (screw+washer) they have been on the manifold	4	1	5

**SFB205818**

No.	Items	Qty.(pcs)	Qty. of spare part	Total	
1	Manifold box	1		1	
2	SFVB (All-glass Evacuated Tubular Solar Collector with Heat Pipe,Φ58mm*1800mm)	20		20	
3	Thermal silicon grease (80g)	1		1	
4	Decoration cover	20	1	21	
5	Vertical bar	2		2	
6	Aluminum horizontal bar	1		1	
7	Black nylon screw cup	20	1	21	
8	Reflectors	19		19	
9	White Nylon clips for reflectors	38		38	
10	screw ,washer and nut	M8×10 (screw,nut,washer)	4	1	5
		M6×10 (screw+washer) they have been on the manifold	4	1	5

**SFB305818**

No.	Items	Qty.(pcs)	Qty. of spare part	Total	
1	Manifold box	1		1	
2	SFVB (All-glass Evacuated Tubular Solar Collector with Heat Pipe,Φ58mm*1800mm)	30		30	
3	Thermal silicon grease (80g)	1		1	
4	Decoration cover	30	1	31	
5	Vertical bar	3		3	
6	Aluminum horizontal bar	1		1	
7	Black nylon screw cup	30	1	31	
8	Reflectors	29		29	
9	White Nylon clips for reflectors	58		58	
10	screw ,washer and nut	M8×10 (screw,nut,washer)	6	1	7
		M6×10 (screw+washer) they have been on the manifold	6	1	7

### 3.2 Fix the Frames and Manifold Box:

#### 3.2.1 Put Side Rails:

Put the 2 side rails as shown below:

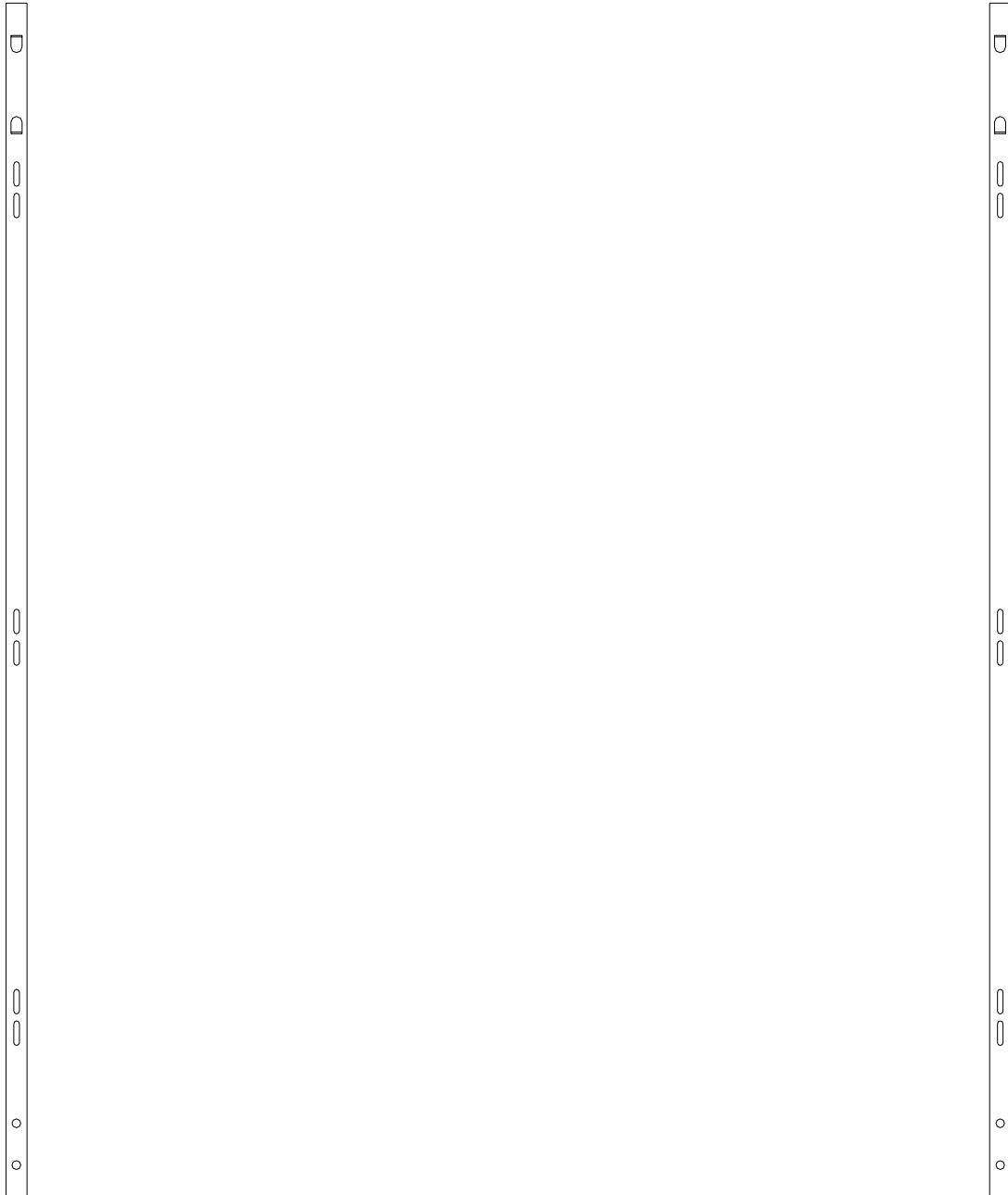

*Fig 3.1*

### 3.2.2 Fix the Manifold:

- a) Put the manifold between the two turnups on 2 side rails;

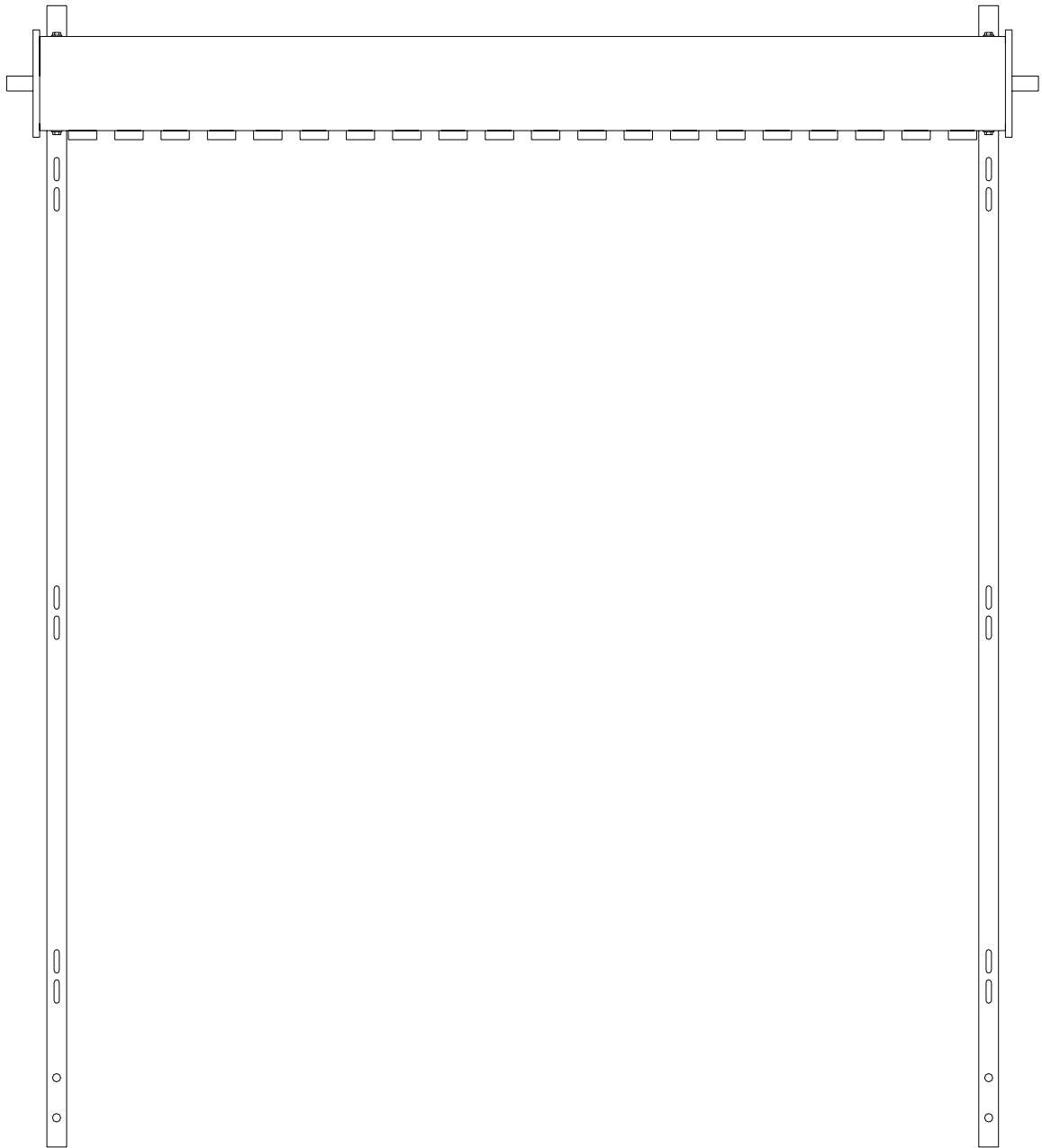

*Fig 3.2*

- b) Fix the manifold to the turnups on the side rails using screws provided. See the following two pictures.



*Fig 3.4*

### **3.3 Fix the bottom rail:**

a) You will find three holes at each end of bottom rail. Screw the screw and nuts through the middle hole and give the screw a black cover. It prevents the tube's cups from sliding off the bottom's rail.



*Fig 3.5*

b) Fix the bottom rail on the vertical bar using the screws.



*Fig 3.6*

### 3.4 Fix solar collector on your sloping roof

#### 3.4.1 Sloping roof

If your roof is sloping, mounting straps will be a useful accessory. You can buy it from us. Or if you can make it by the similar shape or function, it's also ok but please make sure it is strong enough. Our mounting straps are made of SUS304, thickness 1mm.



Fig 3.7

#### Dimension of mounting straps

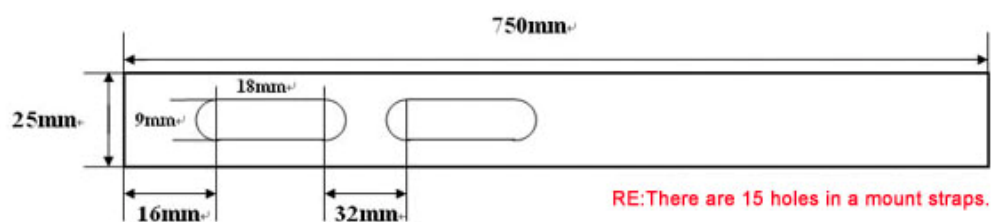

Fig 3.8

#### Installation steps:

- Select a suitable location on the roof for the collector. In the northern hemisphere, the collector should face due south, at an angle to the ground equal to the latitude. For example, latitude of 49 degrees would use a collector angle of about 49 degrees, plus 10 degrees to give best heating in winter.
- Put solar collector on the roof to choose some points to fix screws. These screws are used to fix the mount straps on the roof. Remove roof tiles at the corners of an area large enough to fit the collector.
- Bend mounting straps according to the height of tiles and the location of long-round hole on vertical. Make the bended mounting straps through the gap of two tiles, and fix it on roof by screws. Fix all mounting straps in this way. After that, put solar collector on the roof and adjust the location so that you can fix vertical bar with the bended mount straps by screws. Fix solar collector on mounting straps. (Fig 3.9~3.12).

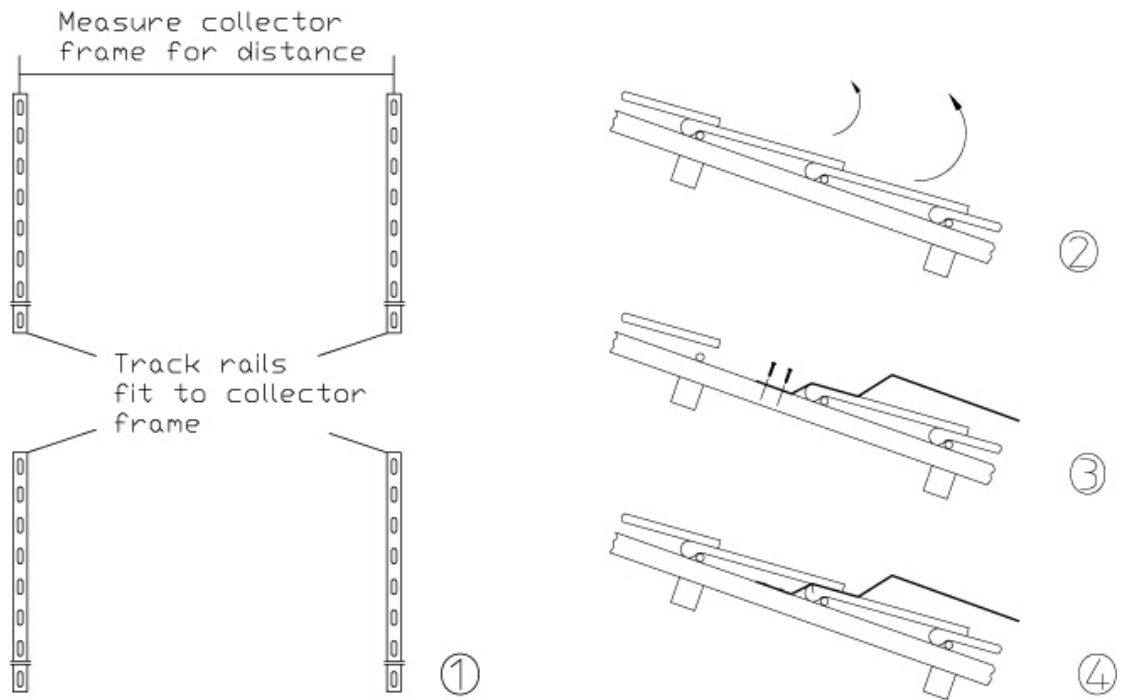

Fig 3.9

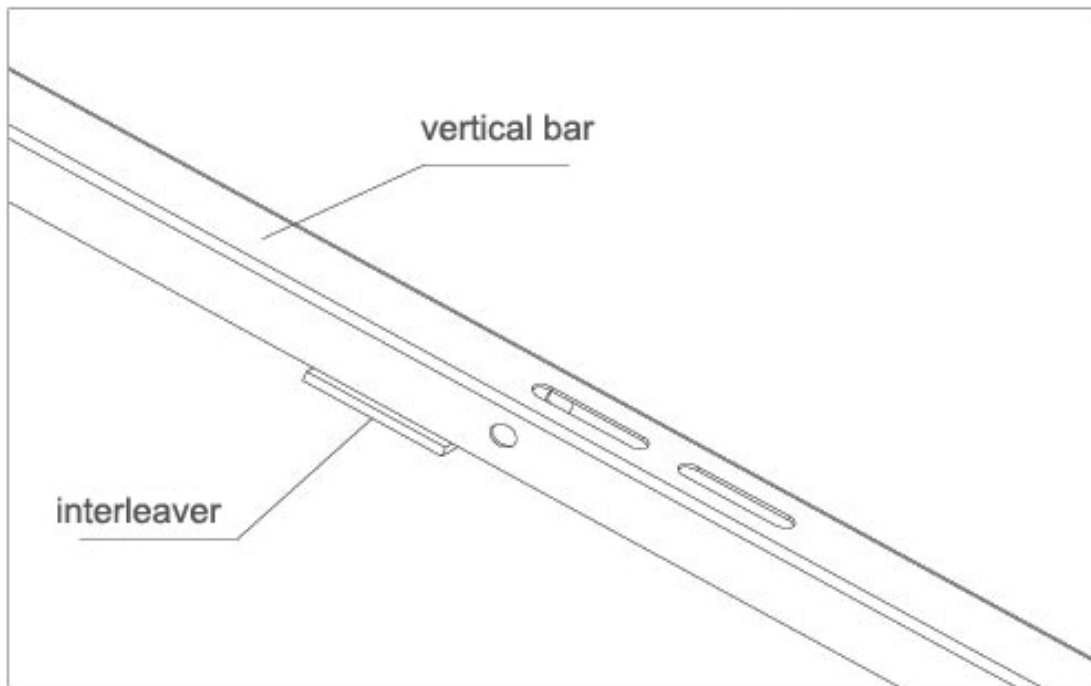

Fig 3.10

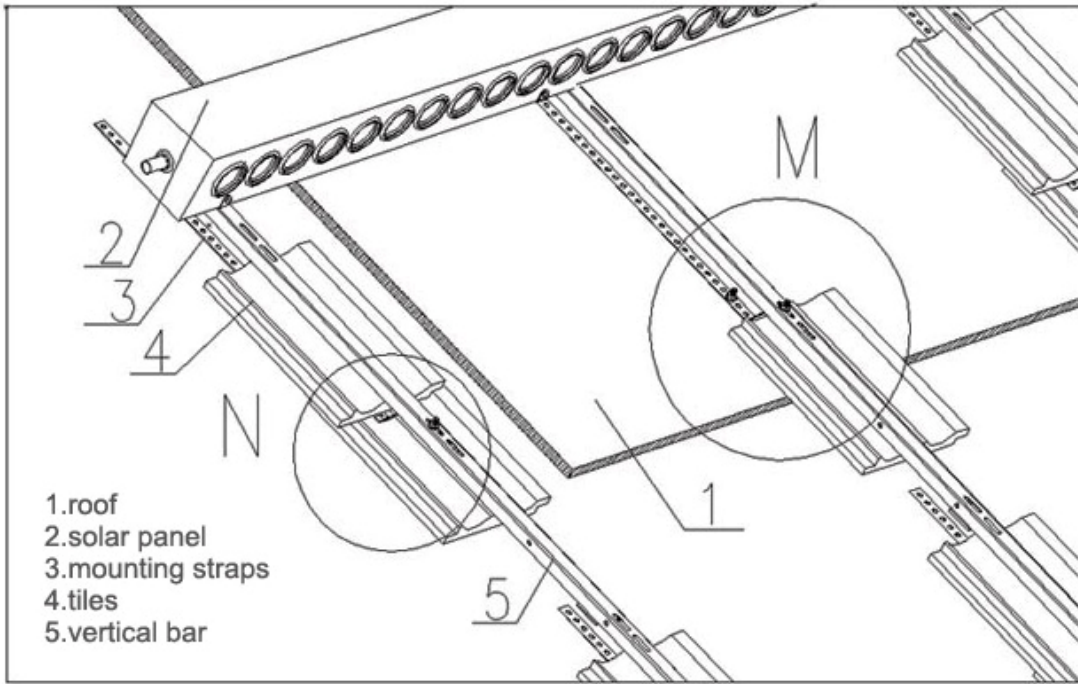
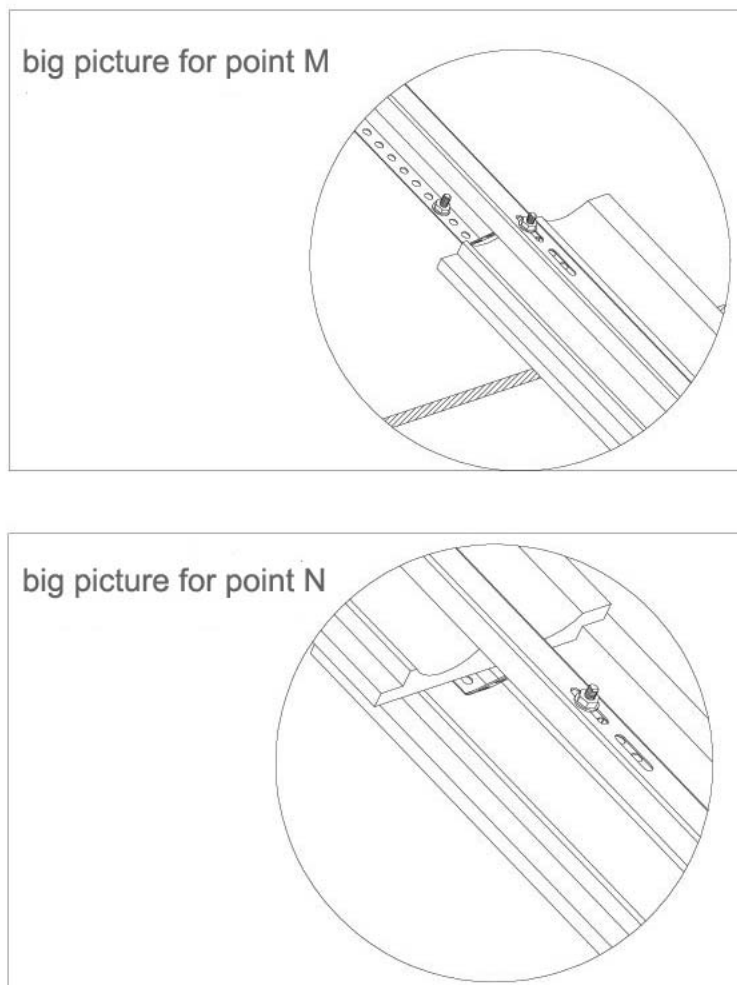

Fig 3.11



*Fig 3.12*

### **3.4.2 Flat roof**

If your roof is flat, you will need a standing frame. Our standing frame is  $40^\circ$ . After install cross bar and connect the standing bar to vertical bar, the collector with standing frame is finished.

Then fix the feet of collector on the roof after insert all tubes.

### **3.5 Install the tubes**

- a) Unscrew the black cups from the bottom rings and clip the rings on the bottom rail, spacing them out evenly



*Fig 3.13*

b) Place the silver end of the evacuated tube through the bottom ring, then slide the copper pipe (covered in the thermal paste) into the slot in the manifold. These can sometimes be a little stiff. Repeat until all your solar tubes are in place.

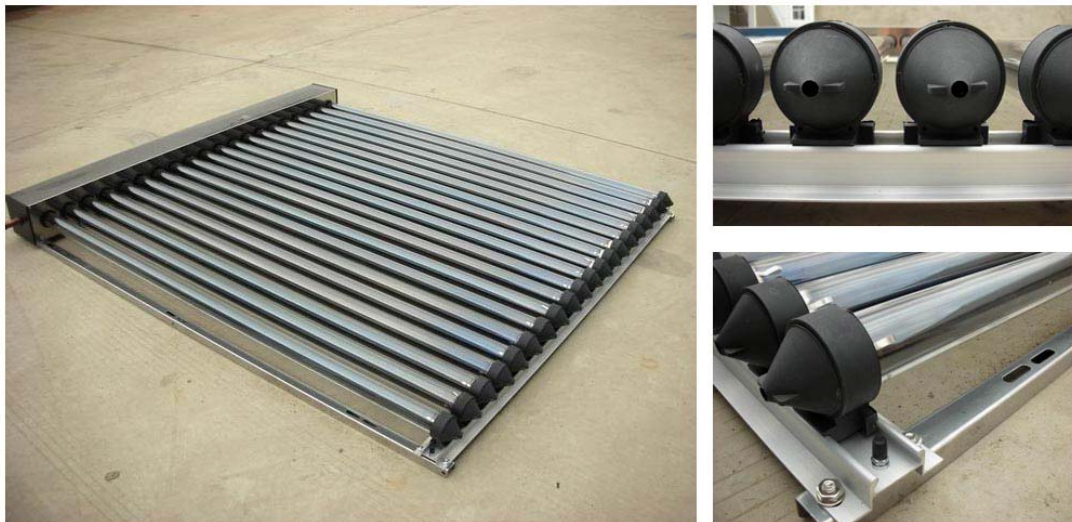

*Fig 3.14*

c) Screw the black cup you removed back into its bottom rings, over the silver ends of the solar tubes until tight. This will hold all the tubes in place. See pics below for greater detail.



*Fig 3.15*



*Fig 3.16*

**Warning:**

If you assemble solar collectors under strong sunshine, or the ambient temperature is high, it's forbidden to touch the two copper pipes' ends by hand directly. Because once tubes are exposed under sunshine, they begin to work. The heat will be transferred to the top of heat pipes in seconds. Therefore, the two ends of copper pipes are very hot after you finished the assembly. Touch it directly will scald skin! You also can cover a blanket to tubes to avoid it.



*Fig 3.17*

**Suggestions:**

1. The assembly process is best to be finished at in the shade.
2. If the process has to be finished under sunshine,you can cover the inserted tubes by black cloth,etc.

**4. Lightning protection**

The collectors should be done lightning protecting to avoid the lightning attacking. The lightning rod is necessary which should be 1.5m higher and 3 m far away from the solar collectors. For any problems that involve plumbing or electrical connections the services of a qualified professional must be employed.

**5. How to connect couple of collectors?**

We suggest you use the corrugated connection pipe to connect every two solar collectors,which is very convenient and completely fit two solar collecots.Please see the following picture.



*Fig 5.1*

**6. Connection of the collector field to the heat transfer circuit**

There're many kinds of heat transfer circulation requirements in actual installatin. Anyway,the following drawing shows the basic situation.

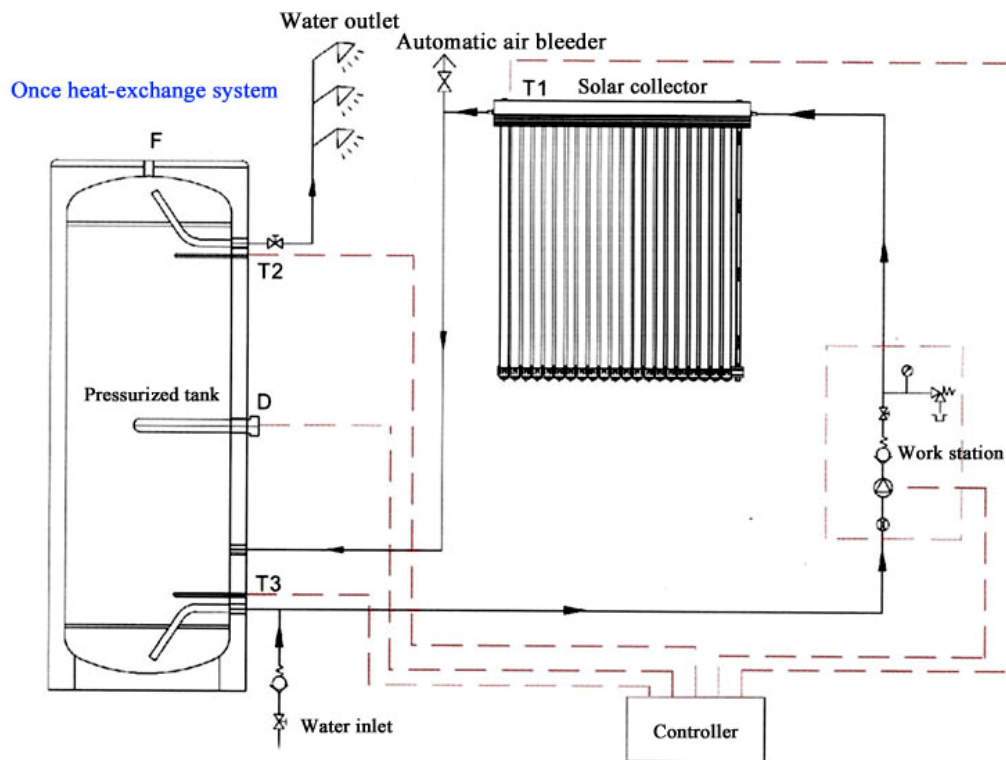

Fig 6.1

Twice heat-exchange system (Single copper coil)

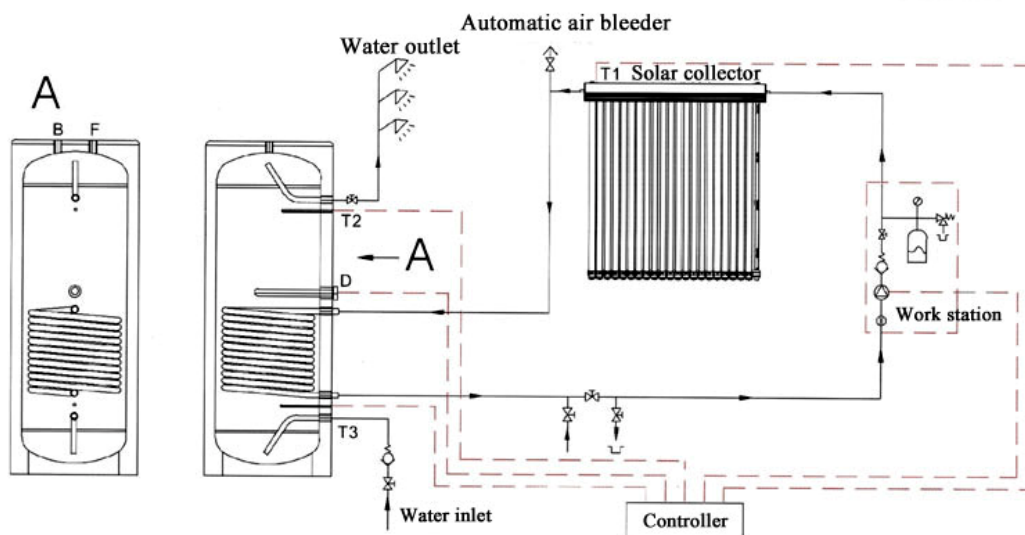

Fig 6.2

### Twice heat-exchange system (Double copper coil)

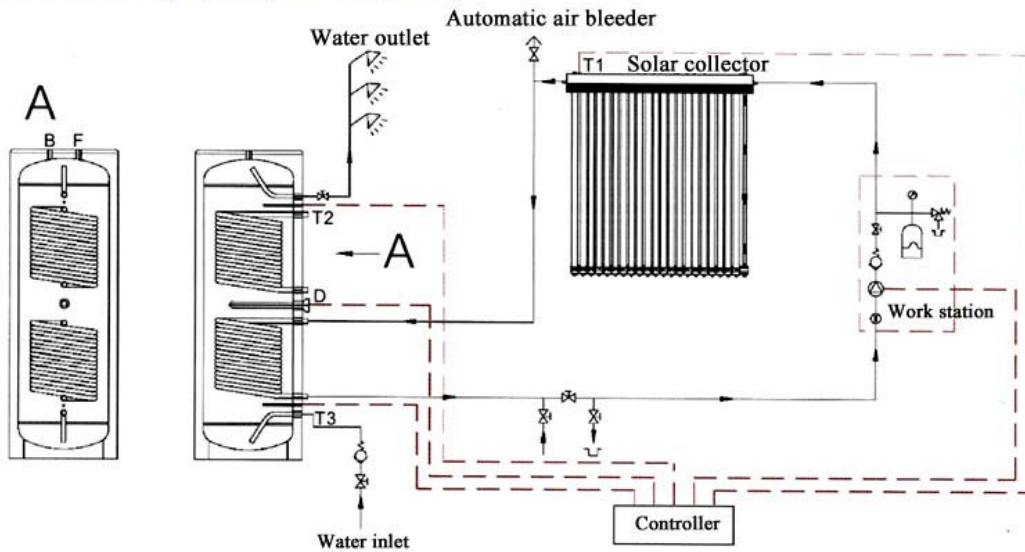

Fig 6.3

## 7. Dimensions of pipe connections

- For solar collector arrays up to 20m<sup>2</sup>, the following dimensions are recommended for the flow and return pipe work:
  - Main pipe lines: 2 inch or 1<sup>1</sup>/<sub>2</sub> inch
  - Branches pipe lines: 1 inch or 3/4 inch
- For a solar installation with pipe work of total length 30 to 50 meters, the following dimensions are recommended for the flow and return pipe work:
  - Less than 36 tubes 12 mm or 1/2 inch-possible, but recommend 3/4 inch.
  - Up to 90 tubes 22 mm or 3/4 inch
  - Up to 120 tubes 128 mm or 1 inch
  - More than 120 tubes – use parallel branches of 1 inch each.

Pipe work should be insulated with 3/4 inch minimum high temperature pipe insulation, more insulation in more extreme cold environments.

## 8. Heat Transfer Media

Any kind of liquid may be heated by the heat exchanger. In areas where chloride ion concentration is greater than 40 ppm a heat exchanger must be used in hot water storage tank. The solar system should be filled with distilled or de-chlorinated water, or another clean fluid such as glycol.

## 9. Precautions

Note: In order to avoid jamming the digital flow meter and in result to display no flow on solar station, the filter( A ) must be installed on the return and flow pipeline of solar station.

All devices connected to the controller must conform to the technical specification of the controller. Assembly, Installation and maintenance work may only be performed by properly qualified and authorized personnel with a generally recognized qualification.

The solar station must be installed indoors, prior to installation, remove sealing caps from solar station.

The maximum distance between solar station and water tank is 300mm, keep top edges of solar station and top edges of storage tank.

Pre-setting, installing and adjusting the expansion tank as per the installation and operation instruction for " expansion tank ", the corrugated connection pipe for the expansion tank does not need thermal insulation.

Safety valve: Risk of scalding from hot steam with discharge from the safety valve due to heating and excess pressure in the hydraulic pipes. Drain off discharge from the safety valve using a copper pipe correctly and in an eco-friendly way, according to valid technical regulations and load codes, do not allow solar fluid to leak into the environment.

Be careful of scald from hot fluid. Maximum temperature of collectors during filling/leak check or installation/maintenance work should be below 70°C, allow collectors to cool down if necessary.

## **10. Max. working pressure**

Regardless of the installation configuration, pressure release valves, expansion vessels and/or other pressure control devices must be installed. The solar loop should be designed to operate at no more than 800kPa (PRV may be 850kPa). (800kPa =8bar=116psi) For installation where mains pressure water is used, the system should ideally be designed to operate at a pressure of <500kPa, achieved by use of a pressure limiting/reduction valve.

## **11. Pressure Drop**

$$\Delta p=0.2\text{Kpa}$$

## **12. Installation Angle**

It is common for collectors to be installed at an angle that corresponds to the

latitude of the location. Installing at an angle less than 20° is not recommended as the heat pipes perform best in the range of 20-70 degree While adhering to this guideline ,an angle of latitude +/-10°is acceptable, and will not greatly reduce solar output. Angles beyond this range may be used, but a decrease in heat output will result. An angle lower than the latitude will enhance summer output, while a greater angle will enhance winter output.

### **13. Wind and snow load**

When installing the collector please consider the issue of wind resistance and the resultant stress on the attachment points. the standard frame is designed to withstand wind speeds of up to 120km/h and 30cm snow accumulation without damage. For the areas with possibility for high winds, additional reinforcement of attachment points may be required and can easily be supplied by your local installers.

### **14. Maintenance Requirements**

#### **14.1 Cleaning**

Regular rain should keep the evacuated tubes clean, but if particularly dirty they may be washed with a soft cloth and warm, soapy water or glass cleaning solution, If the tubes are not easily and safely accessible, high pressure water spray is also effective.

#### **14.2 Leaves**

During autumn, leaves may accumulate between or beneath the tubes. Please remove these leaves regularly to ensure optimal performance and to prevent a fire hazard.(The solar collector will not cause the ignition of flammable materials)

#### **14.3 Broken Tube**

If a tube is broken it should be replaced as soon as possible to maintain maximum collector performance. The system will still operate normally even with a tube broken. Any broken glass should be cleared away to prevent injury.